

Building a new framework for trans-national European research

VIA NORDICA 2008

Helsinki 9 June 2008

Session 2 More cooperation – better research?

Building a new framework for trans-national European research

Tom Warras

R&D Manager, Finnish Road Administration
Work package 3 & 4 leader, ERA-NET ROAD

Co-author: Martin Steward, Highways Agency, UK

Co-author: Christian Pecharda, FSV, Austria

Building a new framework for trans-national European research

- European Research Area
- The ERA-NET ROAD project
- The ERA-NET ROAD toolkit
- The way forward
- Conclusions



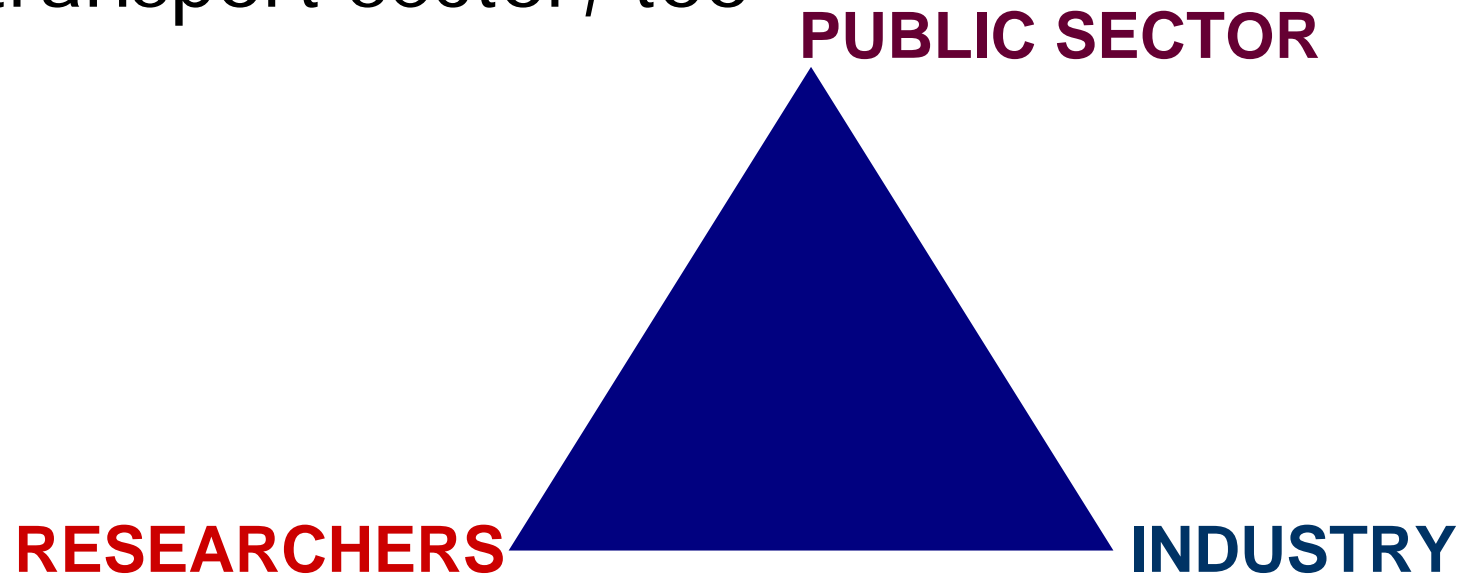







- The European Common Market is reality in the transport sector, too



- The European market of road services is our opportunity – solutions for road users

- 11 National Road Administrations (within CEDR) formed a project **ERA-NET ROAD**
- Objective to build a framework for coordination and management of trans-national road research
- Running from June 2005 until March 2009
- Funded by EU's 6th Framework Programme

The 11 Participants

-  Department for Transport (**Highways Agency**) with the support of TRL
-  Finnish Road Administration (**FinnRA**)
-  Directorate-General of Public Works and Water Management (**Rijkswaterstaat**)
-  Swedish Roads Administration (**SRA**)
-  Federal Ministry of Transport, Building and Urban Affairs (**BASt**)
-  Norwegian Public Roads Administration (**NPRA**)
-  Federal Department for Environment, Transport, Energy & Communication (**ASTRA**)
-  Austrian Federal Ministry of Transport, Innovation and Technology (**BMVIT**) supported by FSV
-  General Directorate of National Roads and Motorways (**GDDKiA**)
-  Directorate of the Republic of Slovenia for Roads(**DRSC**) supported by ZAG
-  Danish Road Directorate (**DRD**)

How to arrive to a good framework for trans-national road research?

- We coordinate road research programmes
- We initiate research collaboration,
- We plan trans-national programmes which are
 - strategically planned,
 - trans-nationally funded,
 - leading to the mutual opening of national research programmes



- The **ERA-NET ROAD TOOLKIT** developed
- Two collaborative **projects** initiated by ERA-NET ROAD are completed successfully; three others ongoing
- A number of proposals for **programmes of research** have been developed based on seven Strategic Research Opportunities (SROs) identified
- One of the programmes is being taken forward: "**Road Owners Getting to Grips with Climate Change**"; eleven NRAs support the programme and provide funding; 1.5 million €.
- An open call for proposals has been made and the **19 project proposals received** are currently being evaluated.

- **Coordination Procedure**
 - What to do? Which topics?
- **Management Procedure**
 - How to do it?
- **Monitoring Procedure**
 - When to do it?
 - Quality assurance



- Identifies the common research needs
- Identifies the partners, i.e. who will benefit from participating in a trans-national action
- The toolkit provides
 - models for strategy alignment and workshopping
 - collaboration models and fair partnership
- Conclusion of ERA-NET ROAD: a driving force for project/programme launching is needed
 - the NRAs to consider who coordinates after ERA-NET ROAD

- Helps to manage a trans-national action
- Trans-national projects and programmes are managed by the lead partners on either side of the

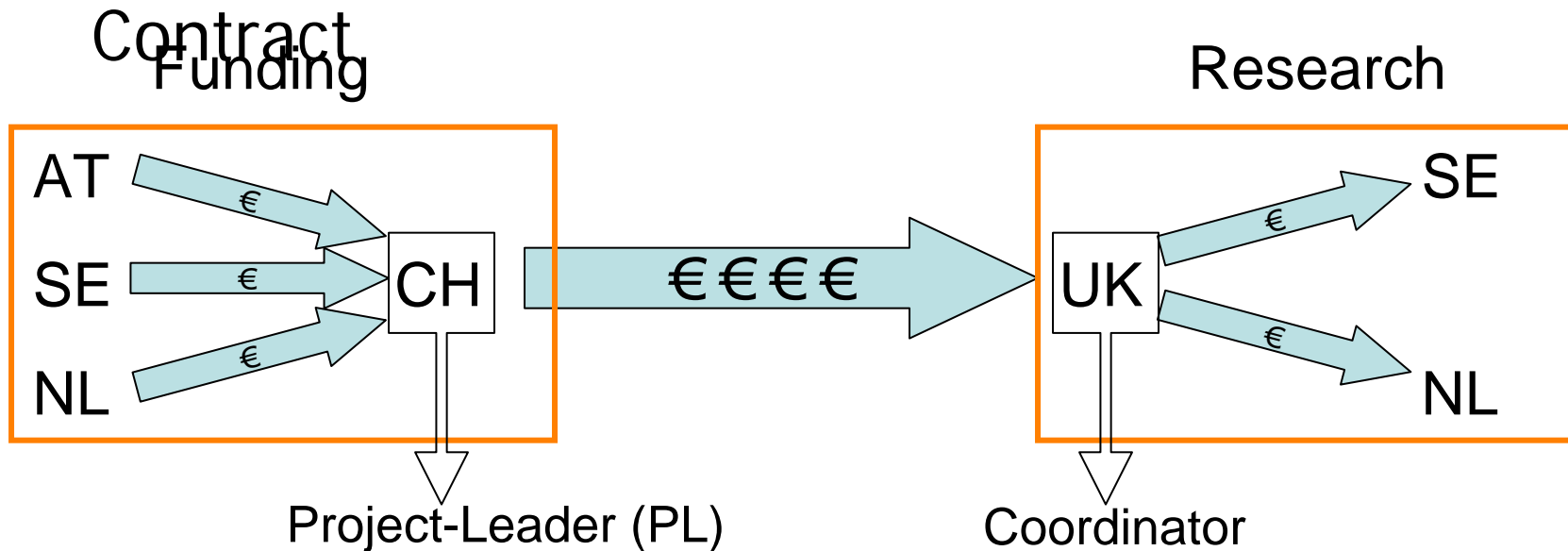

- Helps to monitor a multi-national contract with a multi-national consortium
- The NRAs have different ways of monitoring their research providers: the monitoring procedure defined gives a template suitable for monitoring the performance of the project.

- ERA-NET ROAD will consolidate its procedures
 - in cooperation with CEDR
 - supported by the Commission until March 2009
- Next step ERA-NET ROAD 2 ?
 - new NRAs join in; collaboration within Europe
 - new Joint Programme Calls will be started
 - liaise and align with European stakeholders (Transport Research)
 - a continuity of coordination to be developed and collaboration structures established, hopefully supported by a ERA-NET ROAD 2 period until end 2010

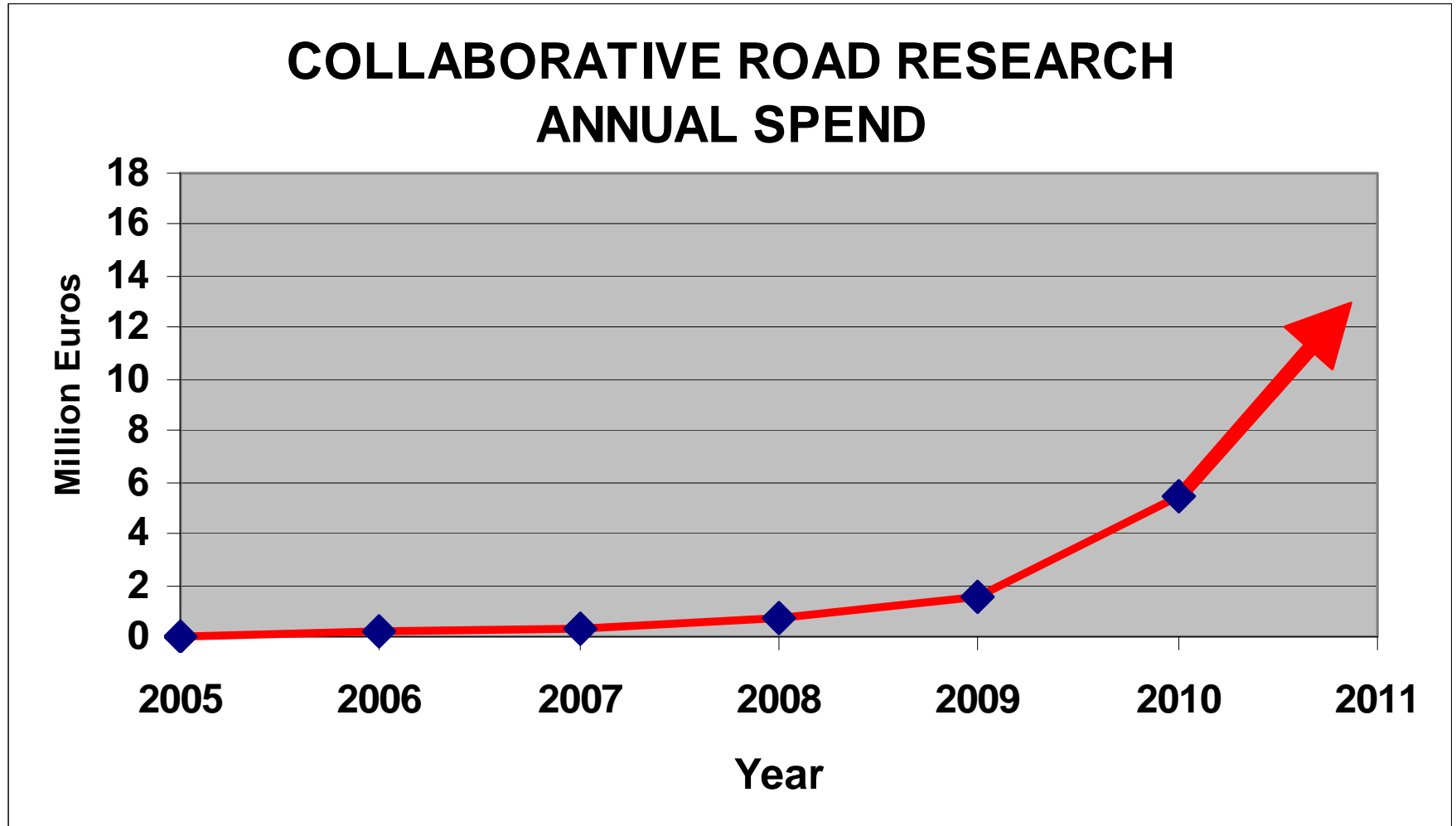

- **Trust.**
- **Understanding.**
- **Commitment.**

- ERA-NET ROAD developed Trust, Understanding and Commitment between NRAs
- ERA-NET ROAD developed a toolkit for the NRAs to use in trans-national research projects
- The toolkit has been and will be tested in numerous trans-national research projects
- A continuous structure of coordination is needed
- Each NRA can develop trans-national research and aim for “business as usual”

- Author: Tom Warras
 - FinnRA Finnish Road Administration
 - tom.warras@tiehallinto.fi
- Co-author: Martin Steward
 - Highways Agency, UK; ERA-NET ROAD Coordinator
 - martin.steward@highways.gsi.gov.uk
- Co-author: Dr Christian Pecharda
 - FSV, Austria
 - pecharda@fsv.at
- <http://www.era-road.net/>